

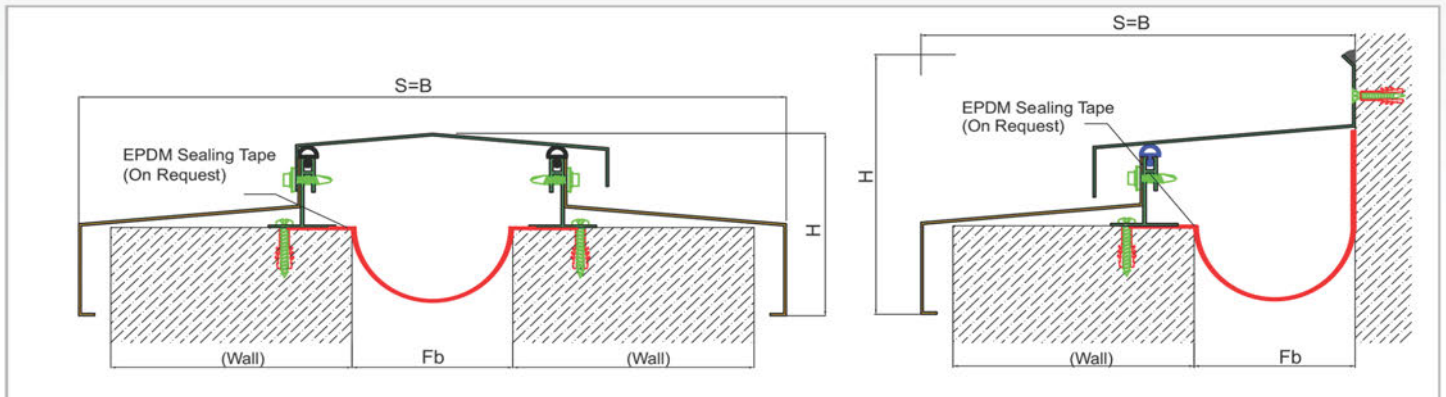

Roof Expansion Joint Covers can simply be defined as the multipartite systems placed on the parapet walls to eliminate the penetration of water, wind and other factors through the expansion gaps at the roofs. They are designed for flat roofs which can be exposed to thermal, structural and seismic movements. To specify the right cover, the parapet wall thickness and gap must be defined correctly and other factors such as seismic ability, wind load, snow load, environmental conditions must be taken into consideration. Covers give a decorative aspect to the roofs with their anodizing finish and can also be powder coated to any RAL color with an additional cost. Cover & side plates of anodized covers are manufactured from hot rolled aluminum while the powder coated ones are manufactured from cold rolled aluminum.

- Application Areas** : Outdoor / Roof
- Ideal for** : All buildings with flat roof
- Material** : Aluminum (Extruded & Hot or Cold Rolled)
- Finish** : Anodized or Powder Coated
- Optional Supplies** : Waterproof EPDM membrane

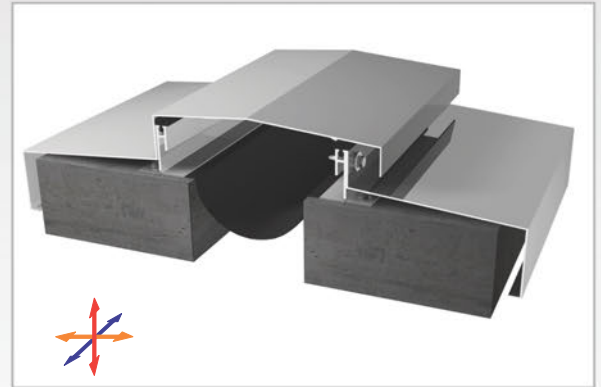
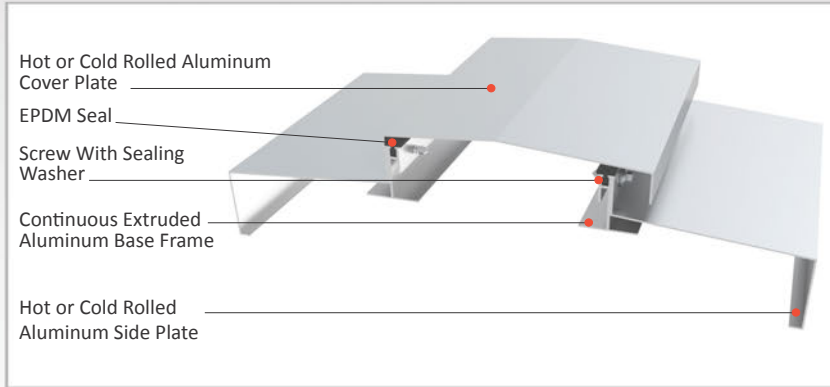

* Visuals are representative and the profile configuration may differ depending on the characteristics requested.

LOCATION	MODEL	GAP (Fb) mm	HEIGHT (H) MM	OVERALL WIDTH (B) mm	VISIBLE WIDTH (S) mm	WALL THICKNESS mm	MOVEMENT (W) mm	STANDARD LENGTH (mt)
Parapet to Parapet	AS UHP 290110	50	110	290	290	100	+16 / -16	3
	AS UHP 440120	100	120	440	440	150	+16 / -16	3
	AS UHP 590120	150	120	590	590	200	+16 / -16	3
	AS UHP 540124	200	124	540	540	150	+16 / -16	3
Parapet to Wall	AS UHP 170155K	50	155	170	170	100	+20 / -20	3
	AS UHP 270170K	100	170	270	270	150	+20 / -20	3
	AS UHP 370173K	150	173	370	370	200	+20 / -20	3
	AS UHP 370177K	200	177	370	370	150	+20 / -20	3

Note: Please ask for different size



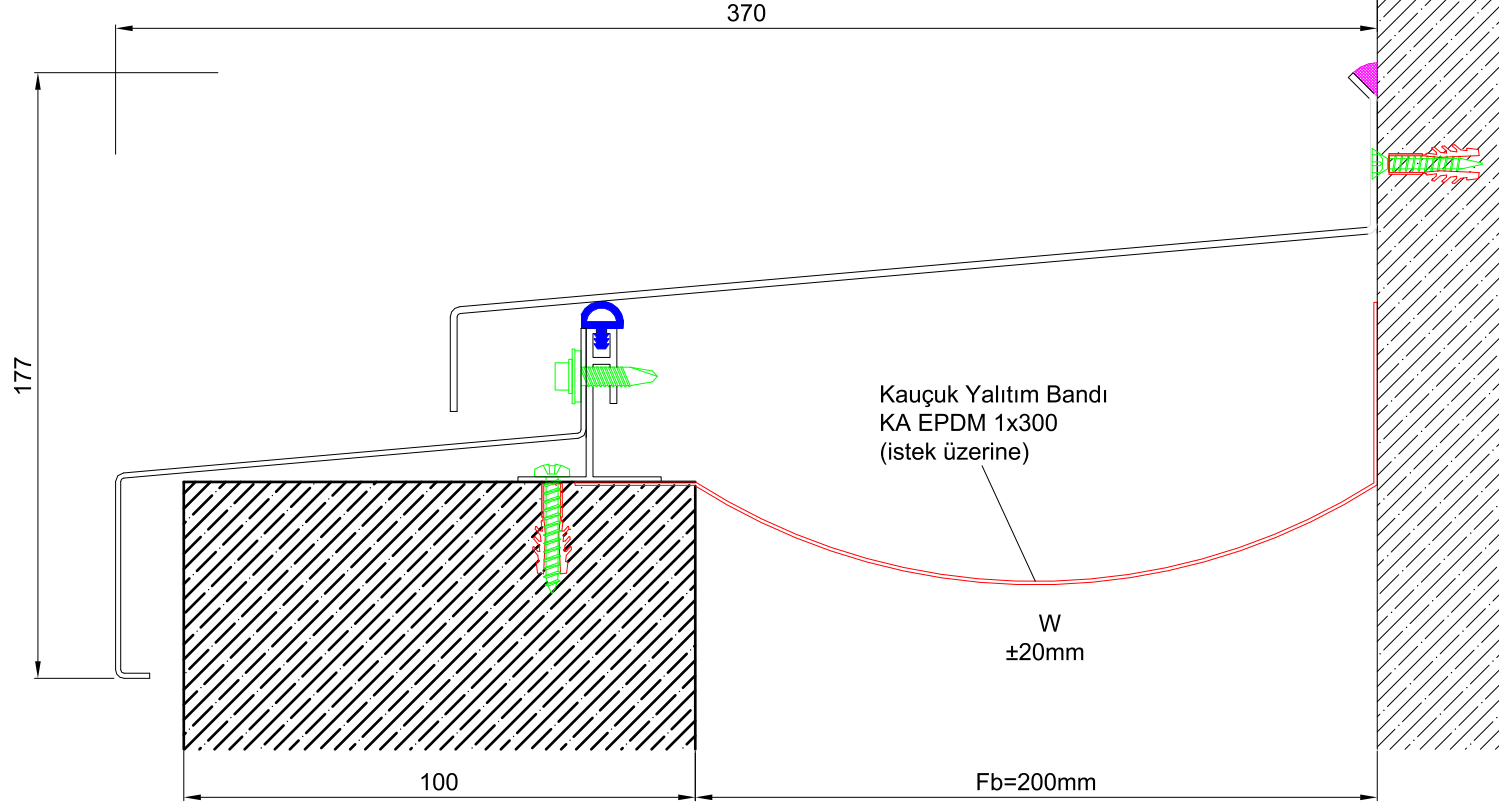

AS UHP 370177K

Profil No Profile Number	AS UHP 370177K
Fb (mm)	200
H (mm) yaklaşık approx.	177
W± (mm) yaklaşık approx.	±20
Renk Color	Alüminyum Görünür Yüzeyler: Elokssalli, Alüminyum Bağlantı Elemanı: Natürel Aluminum Visible Parts: Anodized, Aluminum Base Frame: Natural
Malzeme Material	Alüminyum Aluminum
Standart Uzunluk (m) Standard Length (m)	3